

# **Compact Drive Recessed Mechanism Installation Manual**



*Exclusive Manufacturer of the Hydramatic  
Hydraulic Swimming Pool Covers*

**AQUAMATIC COVER SYSTEMS**  
200 Mayock Rd, Gilroy CA 95020 Ph. 800.262.4044 Fax 408.846.1060

**[www.aquamatic.com](http://www.aquamatic.com)**

## Designed and Engineered by Aquamatic

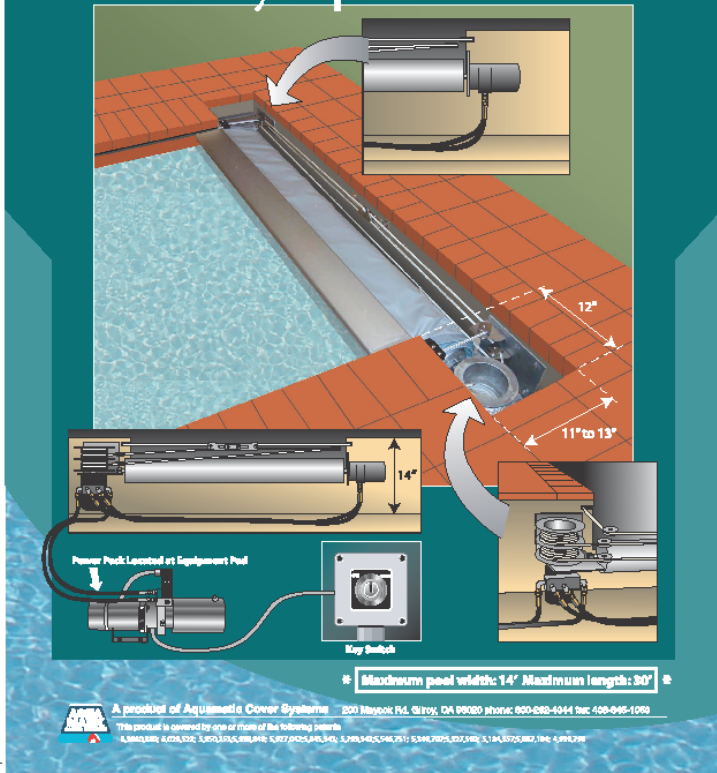

The Compact Hydramatic All Fluid Drive Safety Cover System, is a unique patented system, initially designed for the swim spa applications where the goal was to make the cover system proportional to the reduced size of the vessel. It is now used for all types of pool/spa construction.

### Benefits of Compact Systems

- Only requires 12" (past waterline) offset on both ends of the mechanism housing.
- Ideal for small to medium sized pools. (For larger pools we offer a standard split drive)
- Addresses aesthetics by equaling the offsets, and allows for better coping symmetry around the pool/spa edge.
- The Compact Drive utilizes our proven dual motor hydraulic technology assuring you of the reliability and durability of our hydraulic drive system.

## TABLE OF CONTENTS

<b>Page 1</b>	<b>Preliminary Instructions</b>
<b>Page 2</b>	<b>Assembly of the Hydraulic Hoses &amp; Installation of the Track</b>
<b>Page 3</b>	<b>Assembly of the Compact drive unit</b>
<b>Page 4</b>	<b>Installing the unit in the cover recess &amp; filling the system with Hydraulic Fluid</b>
<b>Page 5</b>	<b>Installing Lid brackets for Masonry, Composite and Aluminum Lids</b>
<b>Page 6</b>	<b>Installing the ropes &amp; Attaching the L.E. bar to the fabric</b>
<b>Page 7</b>	<b>Attaching the cover to the cover drum &amp; pressure Adjustment</b>
<b>Page 8</b>	<b>Skew Adjustment for the cover</b>
<b>Page 9</b>	<b>Electrical Hook-up for the Power-pack</b>

# STEP 1 PRELIMINARY INSTRUCTIONS

## Site Requirements prior to installation

- Make sure cover recess and lowered tile bond beam are clear of any sharp protrusions such as nails, re-bar and debris.
- The cover recess should be 12" deep and 12" wide on the motor side and non motor side.
- Make sure the 2" I.D. "chase" from the equipment pad to the cover is clear and ready to accept the two hydraulic hoses.  
**"Sweep turns only"**  
*(Pulling the hoses through is the first step of the installation process).*
- Make sure the drain is clear and working properly.
- Make sure there is a minimum of 2" of flat-cantilevered coping to secure the track. (This does not apply if using In-wall extrusions).
- Make sure there is a minimum of 1" clearance between the bottom of the coping and the top of the lowered bond beam.

## Tools & Material required

- Hammer Drill with 1/4" masonry drill bits
- Cordless Drill with # 2 & # 3 Philips bit
- 1/2" & 9/16" open wrench and sockets
- Common hand tools such hammer, screwdrivers, hacksaw, file etc....

### The Compact Under Includes:

#### Parts Bag

- Track Screws & Anchors
- Drum Screws
- Compensator Pulley
- Key-stock
- L.E. Bolts (if 3" L.E. )
- \* NO L.E. Bolts ( if 1" x 4" N.S. L.E. )
- Add - Lid Screws (with Aluminum or Composite Lid )

### The Compact Under In-wall Includes:

#### Parts Bag

- Track Screws & Anchors
- Drum Screws
- Compensator Pulley
- \* NO Key-stock
- \* NO L.E. Bolts ( if 1" x 4" N.S. L.E. )

### The Compact Top/Recess Includes:

#### Parts Bag

- Track Screws & Anchors
- Drum Compensator Pulley
- Key-stock
- L.E. bolts
- 2 Top End Pulley A ssembly
- Add - Lid Screws ( with Aluminum or Composite Lid

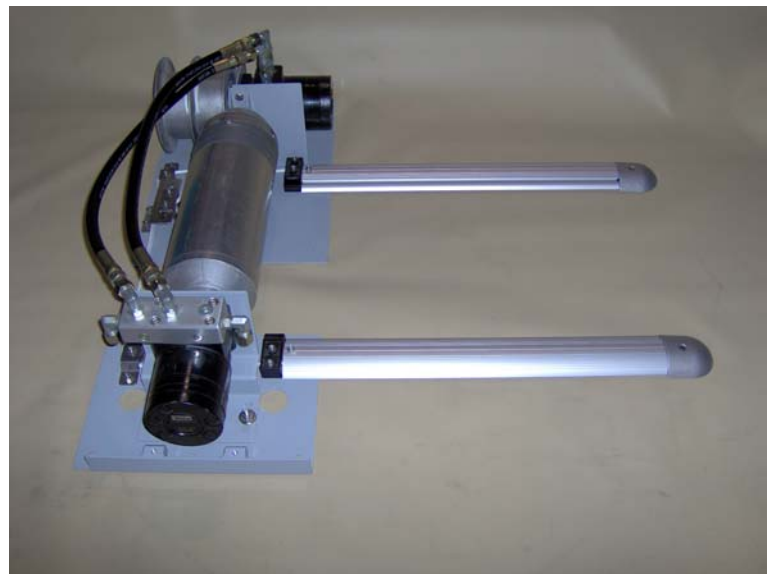
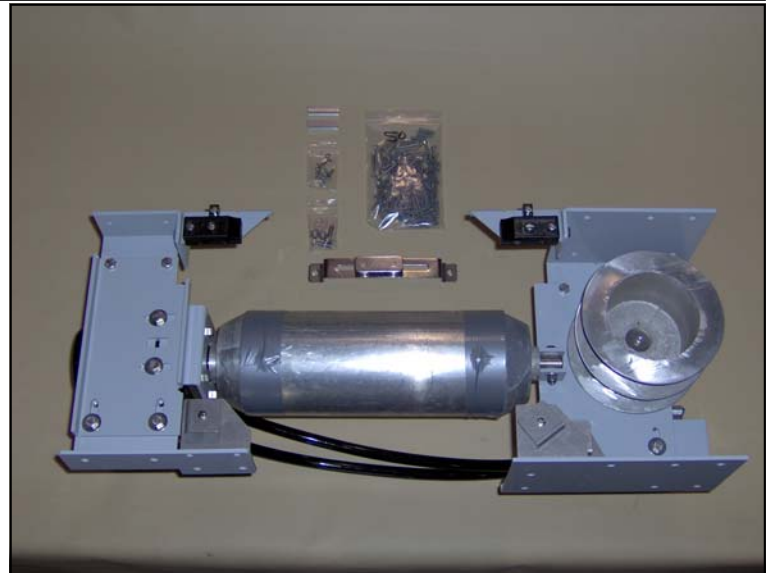

## STEP 2 ASSEMBLY OF THE HYDRAULIC HOSES

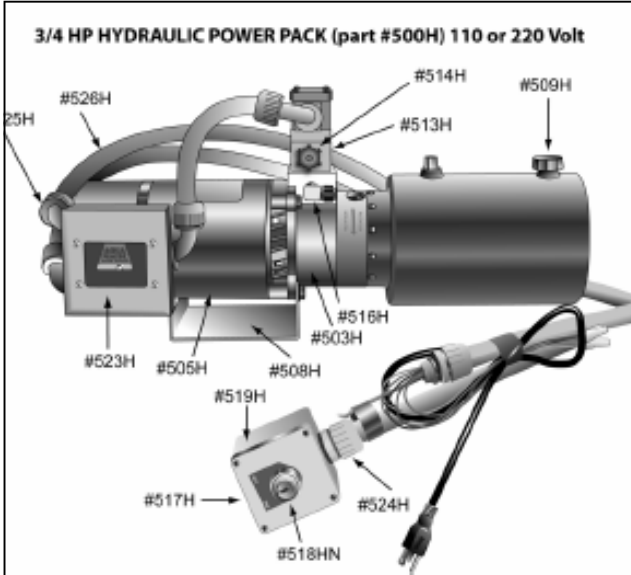

- Make sure the hoses are taped off at both ends to ensure that no water or debris enters the hose, as this can render the system inoperable.
- If the chase is short or straight you may be able to push the hose through, otherwise you will need a fish tape.
- 2' extra required on motor side.
- At equipment pad, there should be enough hose to reach and connect to the power-pack.
- The hoses will come with fittings attached at both ends.

### Hydraulic hose specifications

- 3/8 inch I.D. hydraulic hose
- Working pressure of 1250 to 2250 psi.
- #6-JIC 37 female swivel fittings

## STEP 3 INSTALLATION OF THE TRACK

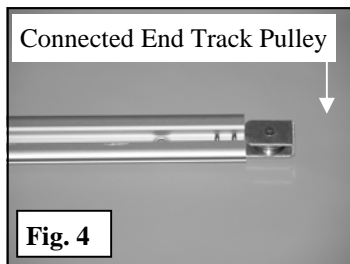
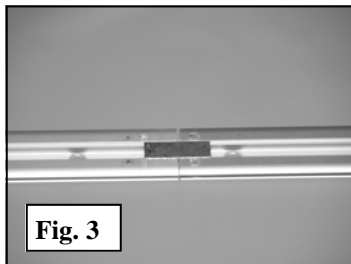
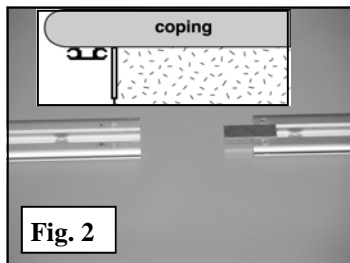
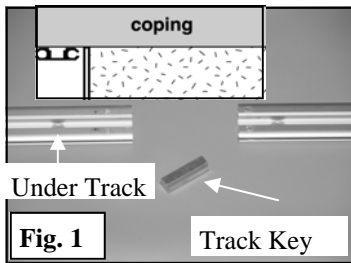

Start with track assembled as shown in fig.4, pulley assembly at the end of the pool opposite the drive end, with the notched side of track facing up.

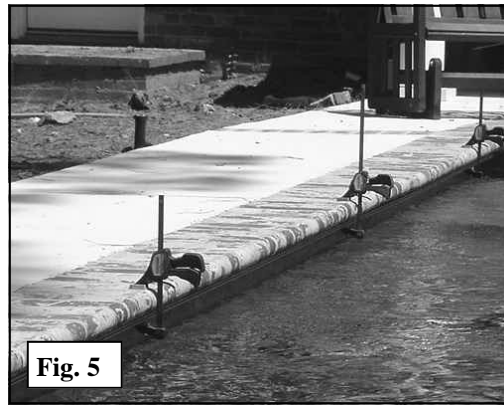

Use C-clamps to secure track under coping. Place pulley end against the tile and track edging along inside of coping, allowing a 1/4" of space between the track and the tiled wall. See fig. 5 to left.

### Drilling and installing track

Using a 1/4" masonry drill bit, drill holes through the pre-punched track holes into underside of coping. Angle drill slightly inward to minimize the chance of breaking the coping. When all holes are drilled remove the C-clamp so that the track hangs down exposing the drill holes. Carefully tap 1/4" plastic into the exposed holes and re-clamp the track. Screw in the #12 x 1 3/4" stainless steel track screws through the track and tighten.

When installing the 2nd piece of **Be sure to leave approx. 1/16" gap between the two pieces of track for thermal expansion.** At the center point, make sure a screw hole is within 2" of the track connection.

The end of track should be cut down to extend into the pit 2 to 3 inches. The last screw in the track at the pit cannot be drilled. This is not a problem and should remain loose for later adjustments. **Please note if tracks are installed prior to plaster, you must tape over track for protection. Use only electrical tape as Other types will leave a residue.** After all the tracks are secured to both sides of the coping, the next step will be to install the mechanism.



## STEPS 4 - 6 ASSEMBLY OF THE COMPACT DRIVE UNIT

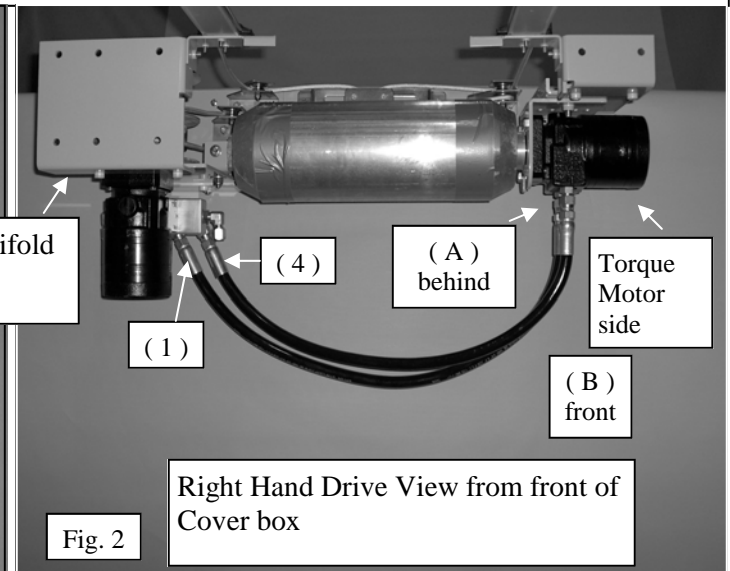
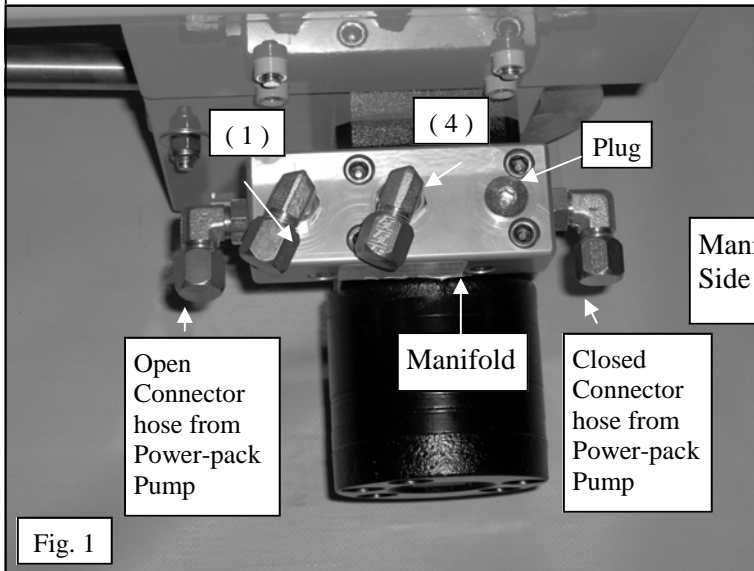

### Step 3

- On the Manifold side above look for “1” & “4”
- On the black torque motors side look for “A” & “B” & Plug

### Step 4

**For RIGHT HAND** drive units, connect a hose from “A” on the torque motor to “1” on the manifold. The other hose will connect from “B” on the torque motor to “4” on the manifold. See Fig. 1 above

**For LEFT HAND** drive units, connect hose from “A” On the torque motor to “4” on the manifold. The other hose will connect from “B” to “1” on the

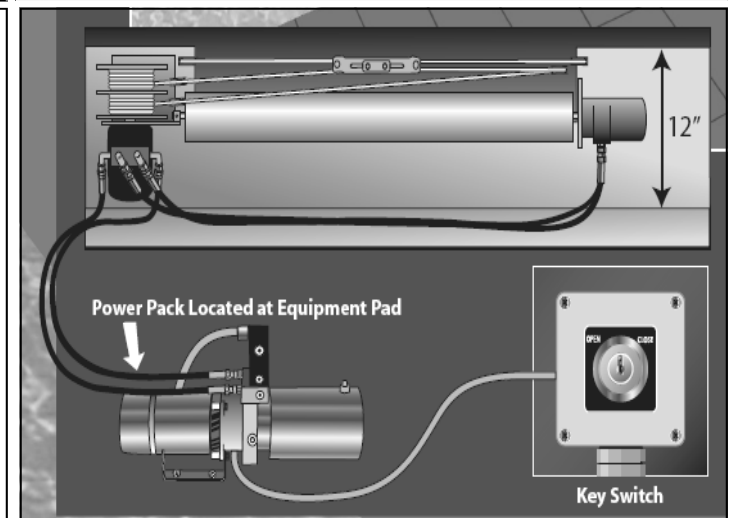

### Step 5

With above hoses connected, you will now connect the two hoses that feed the drive mechanism from the power-pack. Doing this now is much easier than later as it can be difficult to tighten the fittings once the drive unit is mounted. There is no sequence on the hoses from the power-pack to the drive unit.

### Step 6

It is time to set the mechanism into the recess. As with our Hydramatic cover system, this unit is side wall mounted, and does not sit on the floor of the recess. To hold the unit in place, you can clamp it to a cross-brace that would straddle the recess, or block it up from underneath ( to be removed later ).

The drive unit will “self level”, as the end of the track guides (two piece delrin) are already pre-mounted on the integrated guide bracket.

**Make sure the drum is centered to the tracks,** Simply line up the guides with the end of the track. (You may need to adjust the set screw on the stub of the casting to effectively lengthen or shorten the overall length of the mechanism).

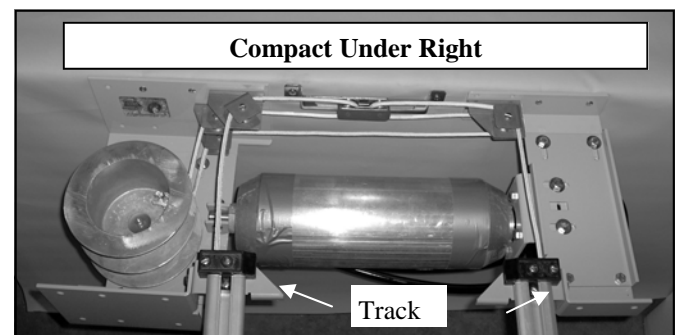

## STEP 7 INSTALLING THE UNIT IN THE COVER RECESS

Once you have the unit at the correct level, drill a 1/4" hole through the tongue of the guide that is resting in the groove of the track. Secure track to guide bracket, making sure that the end of track guide fits right up against the track.

### Step 7 Securing the mechanisms to the wall recess

It is now time to secure the drive end and the rope reel end to the walls of the recess. We have built-in the ability to expand or reduce the overall width of the mounting brackets. If the recess is wider than the mechanism can expand, you will need to shim out the difference on the wall.

Secure the mechanism on each end, to both the front and back mounting plates with the supplied #12 x 1 3/4" st.st. screw and plastic anchors. Four screws per mounting face should suffice.

**Prior to installing the cover** - Before you install the cover vinyl, you will want to cycle the system with the power-pack, as it easier to do this now without the cover.

## STEP 8 FILLING THE SYSTEM WITH HYDRAULIC FLUID

### Step 8 Filling the System with Hydraulic Fluid

The power-pack may be filled with one of the following types of fluids:

**Dexron III Automatic Transmission Fluid**  
**Regular Hydraulic Fluid**

Reservoir holds 3 1/2 quarts of fluid, the hydraulic hoses holding an additional one-quart per each 35 ft. of hose.

You will need: small funnel and rags or paper towels.

1. Remove vent cap, pour in 3 1/2 quarts of fluid using funnel. Screw the vent cap back on.
2. Engage the key switch to the open position for 30 seconds and stop.
3. Remove cap and check fluid level.
4. Fill reservoir within 1" of the top, screw on vent cap.
5. Again turn the key to the open position for 15 seconds.
6. Remove cap and check fluid level until reservoir will not take any more fluid, turn key until cover drum engages.

**After the reservoir is completely full within 1" from the top, you will engage the key in the closed position.**

7. Hold the switch for approximately one minute. **Only turn the key switch in the opposite direction after the reservoir and hoses are completely full of fluid.** This will ensure that the least bit of air as possible gets into the system. Check for any leaks and fix if needed.

### Check for proper switch direction

When the switch is engaged in the "open" position, the cover drum should turn away from the swimming pool. When the key is engaged in the "closed" position, the rope reel take-up reels should be turning towards the swimming pool.

If this is not the case, then simply interchange the "red" and the "blue" wires at the key switch.

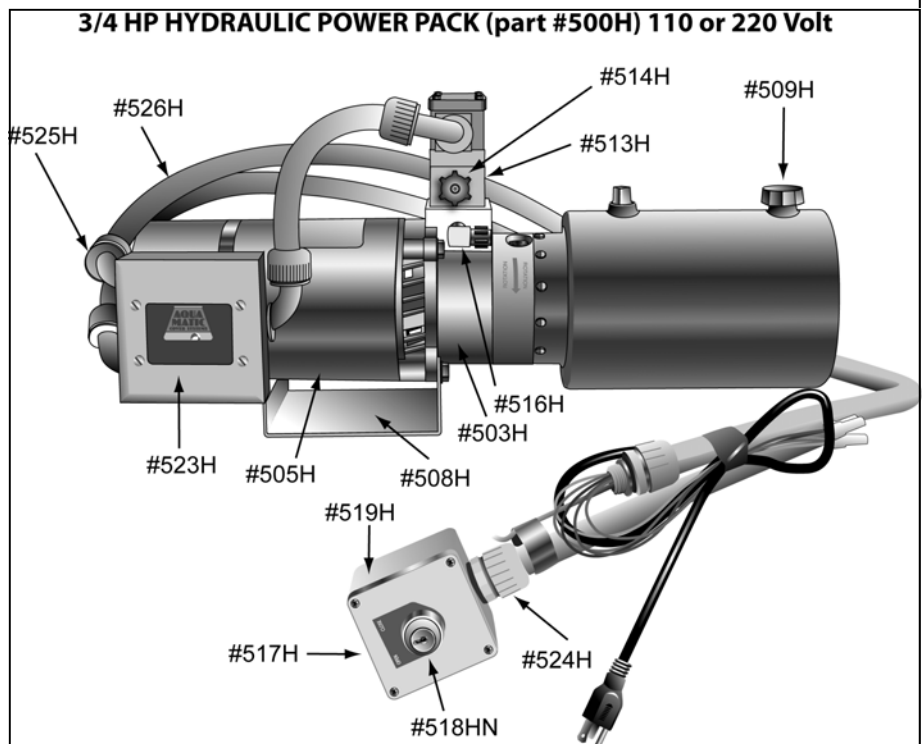

# INSTALLING LID BRACKETS FOR MASONRY, COMPOSITE AND ALUMINUM LIDS

As some of the ropes will run through the gussets of the lid brackets it is required that you mount those now.

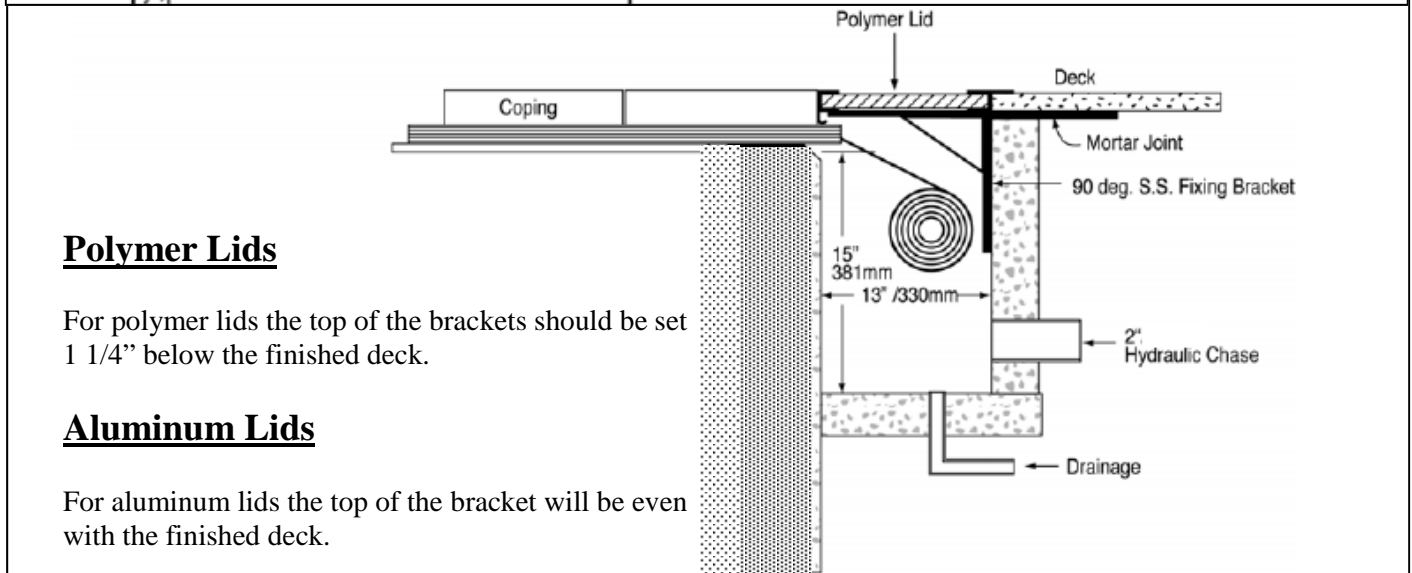
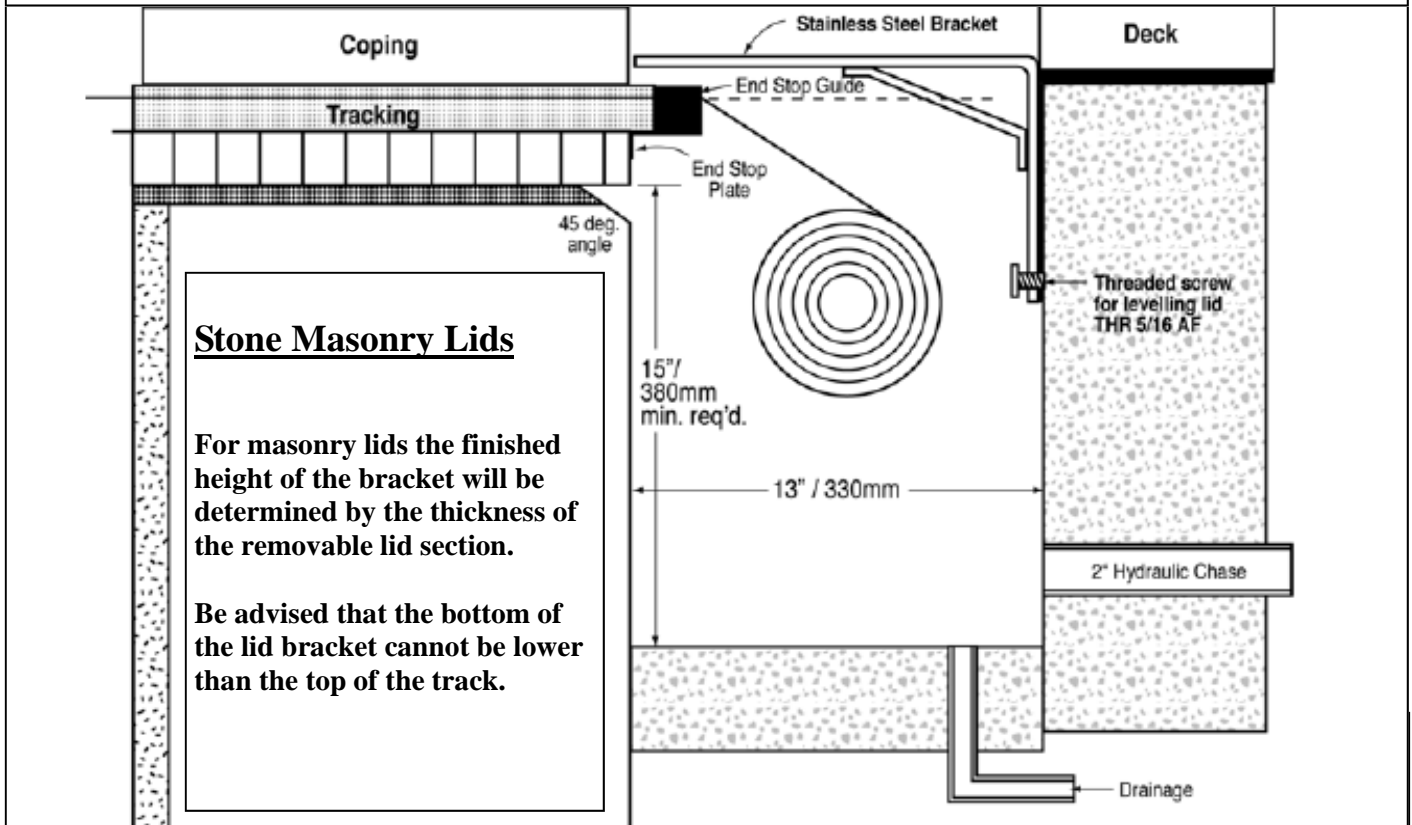

## ROPE PROCEDURE

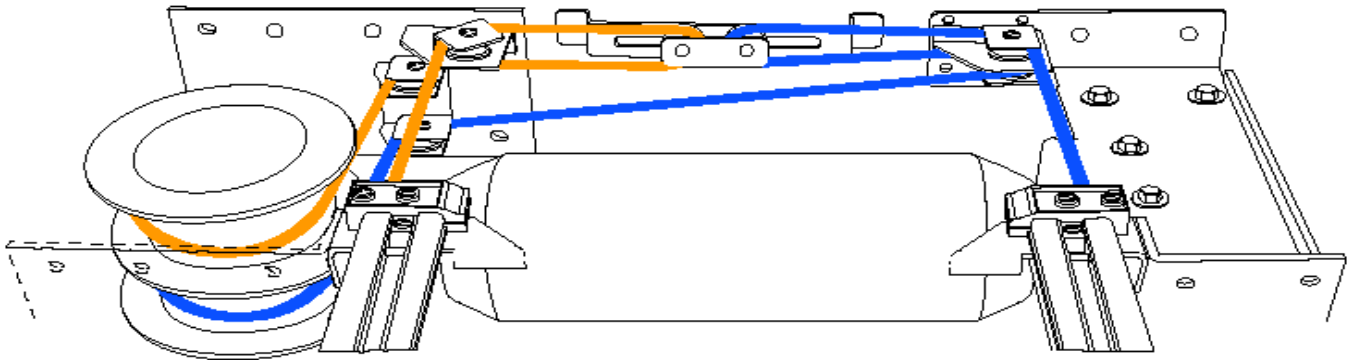

With the system cycling open and closed, you can now install the cover.

**Step 1** - Pull the ropes through the front (water side) channel of the track, around the end pulley, and back to the mechanism through the back (away) channel. Same procedure for both sides.

**Step 2** - Route the ropes through the back pulleys as shown in the above illustration.

**Step 3** - **IMPORTANT DO NOT CUT THE ROPE!**

**Step 4** - Taking hold of both ropes at the same time, manually pull the cover across the pool. If you encounter any resistance stop and locate and correct as required.

## ATTACHING THE LEADING EDGE BAR TO THE COVER

**Note:** Before installing the leading edge, choosing the side you install it on, depends on your surrounding environment. The leading edge must extend into the yard and/or the deck area in order to slide it onto the front

- Slide the Leading Edge bar onto the rope bead at the front of the cover.
- Secure slider to the attaching plate on the bottom of the leading edge bar.
- Make sure to leave the nylox nut slightly loose so the slider can move laterally.
- Feed the slider into the track on each side, about 6".
- Secure track guides on both sides.
- Pulling each rope at the same time, pull the cover across the pool.
- Prior to pulling the rope through the pulleys, you will want to mount your lid brackets as one or more of the ropes will need to run through the lid bracket gusset.

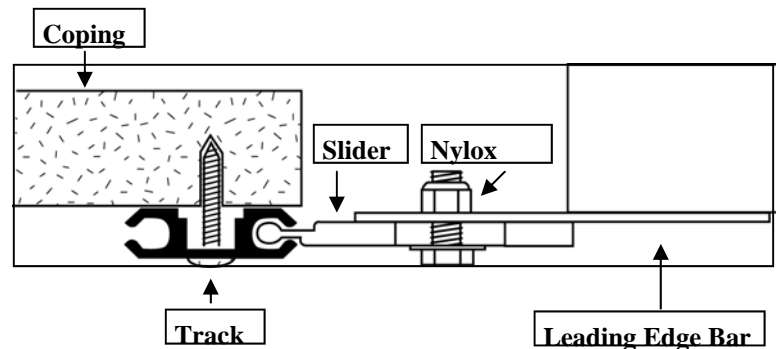



## ATTACHING THE FABRIC TO THE COVER DRUM

### Step 1

- Roll the fabric behind the recess housing.
- Rotate the cover drum until all of the predrilled holes are exposed. (top of cover drum)
- The first step is to attach the outside edges of the cover.
- The first screw will be pushed through on the sew line where the webbing is sewn to the vinyl, do both ends.
- Find your exact center by pulling up the cover, insert center screw with a # 10 x 5/8" Philips pan head screws.
- Working your way from the center to the outside, insert remaining screws while making a pleat on the next to last hole. Repeat on other side
- Turn the key to open for a few seconds, to roll up remaining cover slack.

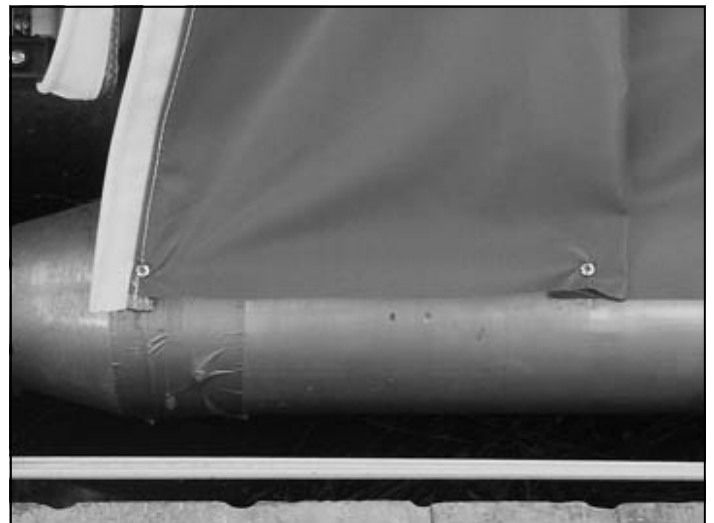

## PRESSURE ADJUSTMENT & SKEW ALIGNMENT

- Locate pressure relieve valve as shown in Fig 1.
- To increase pressure using a 9/16" socket, loosen the jam nut, but do not remove.
- With the jam nut loose, using a 3/16" Allen Wrench turn the set screw clockwise, to increase the pressure.
- Check to see if the cover operates in both directions without hesitation. Repeat if necessary.



## SKIEW ADJUSTMENT COVER ALIGNMENT

*A two to three inch variation on opening side to side is considered an acceptable tolerance.*

**Step 1 -** Prior to adjustment make sure that the cover is fully closed (i.e. fabric covers pool water) before attempting any skew adjustment. Remove pit housing lid.

### Step 2

Loosen (do not remove) the two 9/16 Hex Head Bolts by two complete revolutions on drive unit. Insert a screwdriver into pre-cut slots (see diagram below) adjust roller tube.

### Step 3

Depending on which way the skew needs to be adjusted will depend on which way you move the slots located on the drive unit. If for example, you need to move the leading edge bar towards the pit housing as in **fig. A**, you will need to insert a screwdriver and adjust the slots 1/2" - (10mm) at a time.

### Step 4

Close and reopen the cover and repeat above procedure if more adjustment is required. For surface mounted cover systems: remove the end lid panel above drive unit, loosen the wing nuts and adjust The motor base by hand or by leveraging against a stationary area. The same principal of adjustment as described above applies.

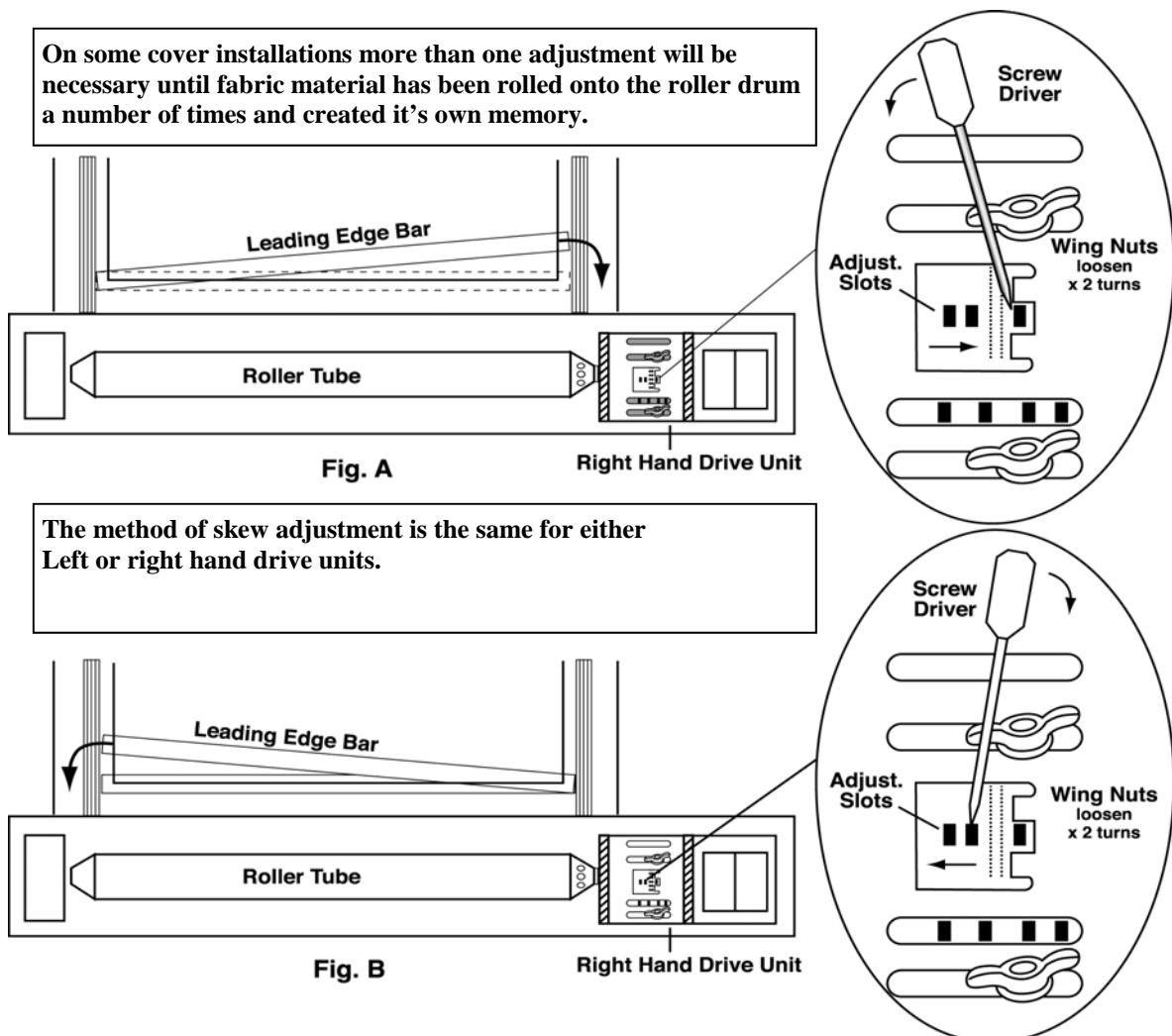

# ELECTRICAL HOOK-UP FOR POWERPACK

## Permanent hook-up for Power-pack (by qualified electrician only)

Wiring the Power-pack requires two circuits:

Circuit # 1 for the key switch and solenoid.  
Circuit # 2 for the motor on the power-pack

**Note: The key switch must be placed in location that allows full view of the cover while operating.**

The power-pack is motor which has the following settings.

3/4 HPs are set at 110v and draws 9 amps  
220v draws 4.5 amps  
1.5 are set at 220v 4.5 amps

**Note:** We suggest always hooking up to 220v. When wiring 220v the key switch must always remain on 110v circuit as the solenoid on the power-pack will be damaged.

## Remote key Switch

- If the key control is remote from the power pack, you must provide a 1/2" electrical conduit from the power-pack to the remote switch location. 12 Gauge wire is recommended on runs over 50'. 14 Gauge for runs less than 50'.
- Have a junction box at the power-pack end of the remote conduit to provide a connection point between the power-pack, liquid tight and the remote wires.
- Four wires are required from the power-pack to the remote key switch location (red, blue, black and yellow).

